

Ceiling Recessed Model-Standard Model
2-Row Cooling, 1-Row Heating

SRC-4SW-DC1-DRC
-Z/P/PW/PC

SRC-4SW-DC1-DRE
-Z/P/PW/PE



240V

Specification

Unit Size		300	400	600	800	1000	1200	1400
Air Volume l/s	H	137	186	251	303	410	498	586
	M	118	161	214	256	352	427	496
	L	91	122	166	190	277	332	368
Cooling Capacity KW	SH	1.1	1.8	2.4	3.0	3.6	4.5	5.3
	TH	1.3	2.2	3.0	3.9	4.4	5.6	6.6
Heating Capacity KW		1.5	2.3	3.0	3.8	4.7	5.7	6.7
Water Flow l/s		0.07	0.11	0.15	0.19	0.21	0.27	0.32
W.P.D. kPa		3	9	17	36	8	14	20
Input Power W		64	72	94	128	159	183	252
Running Current A		0.26	0.30	0.39	0.55	0.67	0.76	1.09
Noise dB(A)	H	43.0	40.5	44.0	46.5	47.5	47.0	50.0
	M	39.5	37.0	41.0	43.0	44.5	43.0	46.0
	L	33.5	31.0	35.5	36.0	29.5	37.0	39.5
Weight kg (without plenum)		19	22	24	28	36	42	45
Weight kg (with plenum)		23	27	30	35	44	55	60
Holding Water Volume L		0.8	1.1	1.3	1.7	2.0	2.4	2.7
Casing		Galvanized Steel						
Fan		Galvanized sheet fabricated, Forward-Curved DIDW Fan						
Motor		3-Speed, PSC with Capacitor Cap and Flexible Conduit						
Power Source		AC240V, 50Hz, Single Phase						
Coil		Slit Surfaced, Aluminum Finned Coil complete with Female Sockets at Inlet/Outlet Conn. And Air Vent						
Operating Pressure		Max 1700kPa (250psig) unless otherwise specified						
Drain Pan		Stainless Steel, SUS430						

Note:

- Cooling capacity is based on DB24°C, WB17.8°C, EWT7°C, LWT12°C.
- Heating capacity is based on DB20°C, EWT60, 20% of the water flow during cooling.
- Cooling/Heating Capacity, Input Power, Running Current are based on H speed.
- Noise is measured at an anechoic chamber, 1m from the unit surface.
- Running current may change according to the conditions.
- Air volume is based on ESP 30Pa.

Dimensions

Without Plenum **SRC-4SW-DC1-DRC-Z** **SRC-4SW-DC1-DRE-Z**
SRC-4SW-DC1-DRC15-Z **SRC-4SW-DC1-DRE15-Z**
SRC-4SW-DC1-DRC24-Z **SRC-4SW-DC1-DRE24-Z**

With Plenum **SRC-4SW-DC1-DRC-P/PW/PC** **SRC-4SW-DC1-DRE-P/PW/PC**
SRC-4SW-DC1-DRC15-P/PW/PC **SRC-4SW-DC1-DRE15-P/PW/PC**
SRC-4SW-DC1-DRC24-P/PW/PC **SRC-4SW-DC1-DRE24-P/PW/PC**

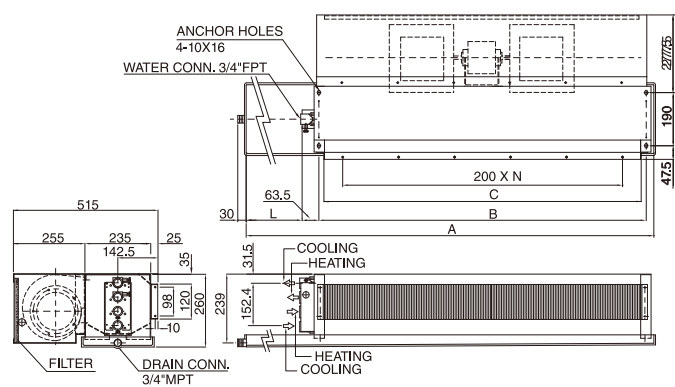
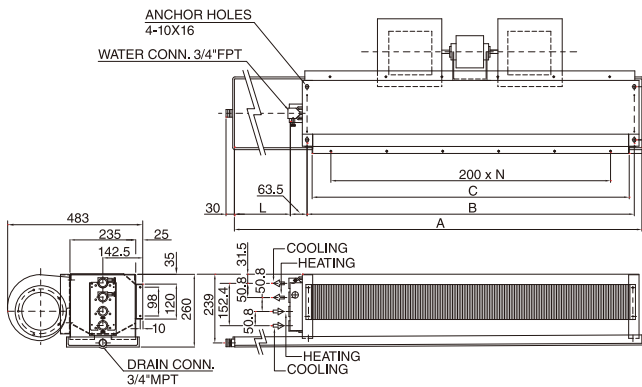

Unit Size	-Z/P/PW/PE/PC		15-Z/P/PW/PE/PC		24-Z/P/PW/PE/PC		B	C	N	NO. OF FAN	NO. OF MOTOR
	A	L	A	L	A	L					
SRC- 300-4SW-DC1-DRC(E)	635	50	785	200	875	290	500	462	2	1	1
SRC- 400-4SW-DC1-DRC(E)	885	50	1035	200	1125	290	750	712	3	2	1
SRC- 600-4SW-DC1-DRC(E)	1020	50	1170	200	1260	290	885	847	4	2	1
SRC- 800-4SW-DC1-DRC(E)	1305	50	1455	200	1545	290	1170	1132	5	2	1
SRC-1000-4SW-DC1-DRC(E)	1490	50	1640	200	1730	290	1340	1302	6	3	2
SRC-1200-4SW-DC1-DRC(E)	1740	50	1890	200	1980	290	1590	1552	7	4	2
SRC-1400-4SW-DC1-DRC(E)	1920	50	2070	200	2160	290	1770	1732	8	4	2

Note:

- Left hand unit is shown.
- Furnish access door to service fan motor.
- Wiring works between motor and switch, and unit to power source by contractors.
- Unit shall be mounted horizontally.
- To prevent condensation, fan interlock valve shall be furnished so that water supply will be stopped when fan is off.